

μCMM

Measure components with extremely tight tolerances in high accuracy

μCMM is the most accurate purely optical micro-coordinate measuring system in its class. Users combine advantages from tactile coordinate measuring technology and optical surface measuring technology and measure the dimension, position, shape and roughness of components with only one sensor. The optical CMM offers high geometric accuracy of several optical 3D measurements in relation to each other, enabling the measurement of small surface details on large components and precisely determining the position of these individual measurements in relation to each other. The spectrum of measurable surfaces includes all common industrial materials and composites such as plastics, PCD, CFRP, ceramics, chrome, silicon. Materials from matte to polished, reflective components can be measured. Simple operation is implemented by single-button solutions, automation and ergonomic control elements such as a specially designed controller. Air-bearing axes with linear drive enable wear-free use and highly accurate, fast measurements. This makes μCMM ideal for permanent use in production, too.

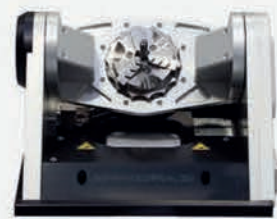

AdvancedReal3D RotationUnit G2



Real3D Rotation Unit G2



RotationGrip



RinglightHP



AdvancedInsertGrip



InsertGrip G2



ToolGrip



GENERAL SPECIFICATIONS

Number of measurement points	Single measurement: X: 1720, Y: 1720, X x Y: 2.95 million Multi measurement: up to 500 million
Positioning volume (X x Y x Z)	310 mm x 310 mm x 310 mm = 29 791 000 mm ³
Compressed air	maintenance-free with compressed air according to specification, 6 bar
Travel speed of axes	up to 100 mm/s
Coaxial illumination	LED coaxial illumination (color), high-power, electronically controllable
Objective changer	automatic pneumatic four-place objective changer
System monitoring	9 temperature sensors (accuracy: ± 0.1 K), 3 vibration sensors, internal current and voltage monitoring, incl. long-term logging, retrievable
ControlServerHP	4 Core, 32 GB DDR4, HDD 2 TB, Windows 10 IoT Enterprise 64bit, 2x 27" Full HD LED Monitor

DIMENSIONS

Dimensions (W x D x H)	measurement instrument: 960 x 1109 x 1958 mm (up to 2288 mm); ControlServerHP: 200 x 490 x 440 mm
Mass	measurement instrument: 1250 kg (incl. steel stand); ControlServerHP: 16.9 kg

MEASUREMENT OBJECT

Max. weight	30 kg; more on request
Max. dimensions	width: 680 mm, height: 375 mm

ACCURACY

3D Accuracy 10360-8 (*)		$E_{inhTrDOSMPE} = (0.8 + L/600) \mu\text{m}$ (L in mm) (**) $E_{inhZStDOSMPE} = (0.15 + L/50) \mu\text{m}$ (L in mm) (***)
Flatness deviation	1.6 mm x 1.6 mm with 10x objective	U = 0.1 μm
Profile roughness	Ra = 0.1 μm Ra = 0.5 μm	U = 0.012 μm, σ = 0.001 μm U = 0.02 μm, σ = 0.001 μm
Areal roughness	Sa = 0.1 μm Sa = 0.5 μm	U = 0.01 μm, σ = 0.001 μm U = 0.015 μm, σ = 0.001 μm
Wedge angle	β = 70° - 110°	U = 0.075°, σ = 0.01°
Edge radius	R = 5 μm - 20 μm R > 20 μm	U = 1.5 μm, σ = 0.15 μm U = 2 μm, σ = 0.3 μm

(*) The values given are based on ISO 10360-8 and VDI 2617.
(**) Valid for all MultiMeasurements.
(***) Valid for single measurements, height step measurements.

OBJECTIVE SPECIFIC FEATURES

Objective magnification		5x	10x	20x	50x	100x
Working distance	mm	23.5	17.5	19	11	4.5
Lateral measurement range (X, Y)	mm	2.63	1.32	0.66	0.26	0.13
	mm ²	6.91	1.71	0.43	0.06	0.01



Spezifikationen in blau stehen für Alicona spezifische Werte.

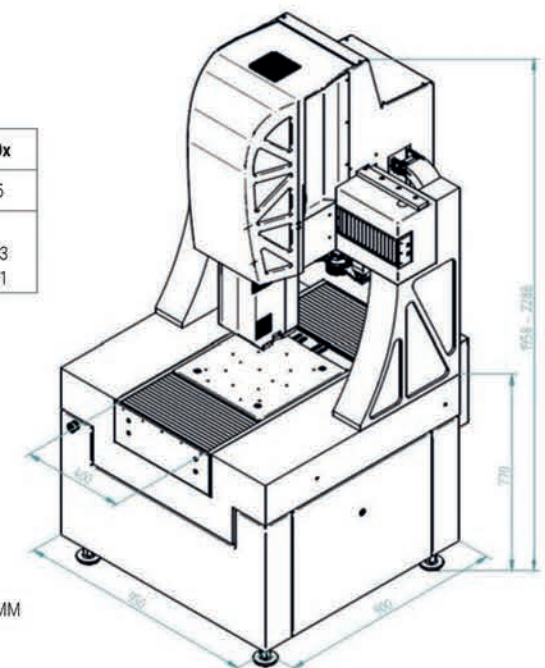

Isometric view - μCMM